



Wakely 350 Model Electric Dry Roller

- High quality precision balanced Solid Chilled Rollers
- Working surfaces are 50 - 54 Rockwell hardness
- Output per hour Dry Rolled 3 - 4 tonne per hour
- Heavy duty ball bearings
- Parallel roll gap adjustment
- Driven by (2) 7.5 KW Motors
- Heavy duty fabricated frame

The Wakely Mill

Synonymous with durability for over 25 years all our mills feature Solid chilled Rolls. The rolls are solid chilled, made by the centrifugal casting process and use a double pour technique. They cannot be compared with mild or hardened steel rolls and with annual maintenance, chilled rolls last indefinitely. The rolls are balanced to a degree that vibration is almost eliminated and with the inclusion of sound deadening pads leads to any extremely low noise, low vibration machine, thus extending mill life and improving the working environment

WAKELY ENGINEERING LIMITED, ESSEXFORD, LOUTH, DUNDALK, CO. LOUTH, IRELAND

Tel: 00353 (0)42 9374388 Fax: 00353 (0)42 9374669 Email: info@wakelyengineering.ie Web: www.wakelyengineering.ie

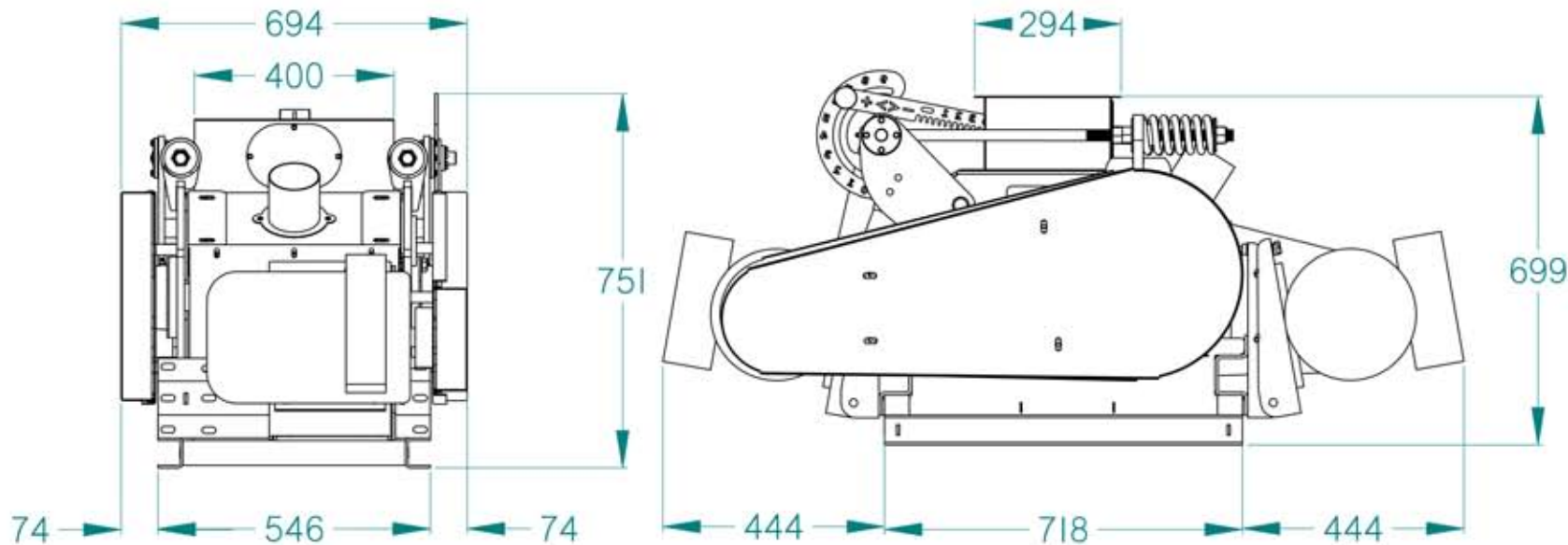

Adjustment made simple with the Unique Wakely Parallel roll gap adjustment lever.



Feed Spreader Flap: Ensures a continuous even flow of feed.

WAKELY DRY ROLLER/MILLS - THE YELLOW ONES THAT EVERYONE IS TALKING ABOUT!

UNIQUE WAKELY FEATURES:

- Precision balanced chill hardened SOLID rollers - Working surfaces are 50-54 Rockwell hardness - Heavy duty 55mm ball bearings
- Smooth running LOW NOISE efficient rollers with no roller to roller contact
- Simple parallel roll gap adjustment with single levers - NO SPANNERS!!

WAKELY MILLS AS SUPPLIES TO THE FARMING AND MILLING INDUSTRY FOR OVER A QUARTER CENTURY

“REVOLUTIONARY SOLID EDGE TECHNOLOGY IS USED IN THE DESIGN AND MANUFACTURING PROCESS OF THE WAKELY RANGE OF ROLLERS”

Anything you can combine a Wakely Mill can crush - “SUPPLIERS TO THE LEADING MILLERS AND CONTRACTORS ON THE IRISH AND UK MARKET”